

VHF Transmitter Family R&S NM/NW7000

Liquid-cooled transmitters for analog and digital TV (DVB-T or ATSC)

- ◆ Frequency range
170 MHz to 250 MHz
- ◆ MOSFET technology for
power amplifiers
- ◆ Digital precorrection
- ◆ Liquid-cooled
- ◆ High redundancy
- ◆ Highly compact for minimum
space requirements
- ◆ Cost-effective installation
- ◆ All standby concepts possible (single
transmitter, active or passive output-
stage standby, exciter standby)



ROHDE & SCHWARZ

A new VHF generation of transmitters

At a glance

With the TV Transmitter Family R&S NM/NW7000, Rohde&Schwarz has developed a new generation of liquid-cooled VHF transmitters for analog and digital TV (**DVB-T or ATSC**). They consist of the following main components:

- ◆ Exciter
- ◆ Power amplifiers incl. power supply
- ◆ Transmitter rack

The VHF transmitters are available for analog TV with powers of 2 kW to 20 kW and for DVB-T with powers of 900 W to 7.2 kW or ATSC with 1.5 kW to 11.5 kW (higher power ratings on request). Each amplifier has its own power supply which is integrated into the amplifier module and thus cooled by the liquid cooling system.

The amplifier module is self-engaging and can be exchanged during operation without any liquid loss of the closed cooling system and without impairing the operation of the other modules.

The power supplies are fed with AC supply voltage, i.e. no auxiliary voltage supplies are required, which improves the availability of the transmitters. Parts exclusively made of stainless steel, aluminium or plastic are used for the cooling system in the transmitter rack.

All transmitters can be equipped with a second exciter and the associated automatic switchover unit, the two units being integrated into the transmitter rack.

Transmitter rack

The transmitters with a maximum output power of 10 kW for analog TV, 3.6 kW for DVB-T or 5.8 kW for ATSC are accommodated in a rack 630 mm in width. This means space requirements are at a minimum since also components such as the harmonics filter, the vision/sound diplexer and the colour subcarrier trap for analog TV are accommodated in the transmitter rack. The bandpass filter for DVB-T or ATSC application is mounted outside the transmitter rack. To obtain higher power further racks fitted with the necessary amplifier plug-ins and couplers are required.

The connectors for modulation lines (VF, AF or TS), for example, as well as the remote control interface etc are located on the top of the transmitter rack.

The connectors for the cooling system can be either on the top or bottom. The tubing used throughout the cooling system is of uniform cross-section to avoid different flow rates and thus blocking.



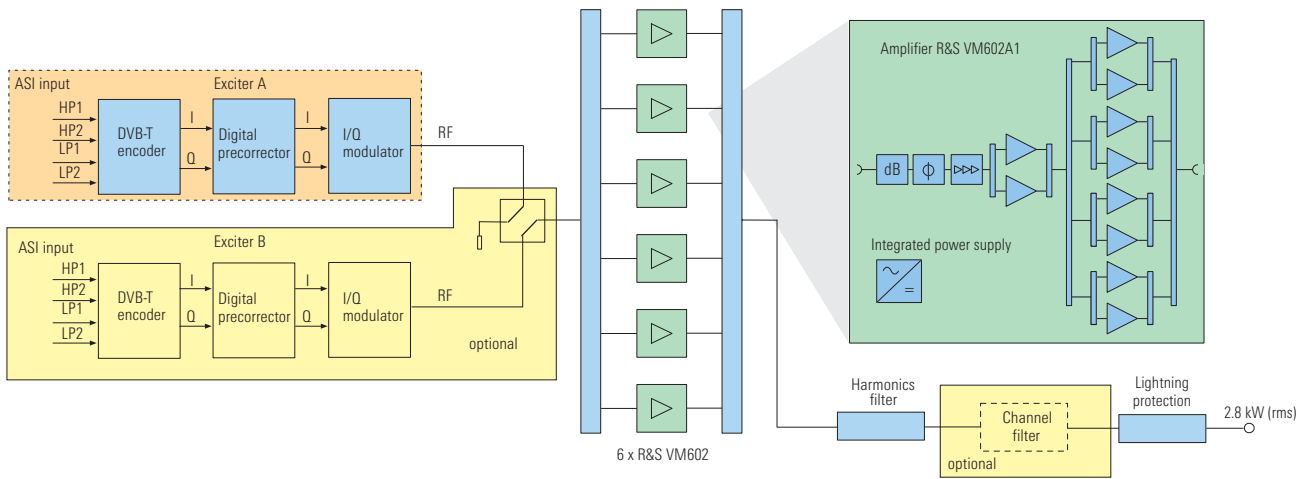

Block diagram of 2.8 kW DVB-T transmitter or 4.4 kW ATSC transmitter



Power amplifiers

Thanks to MOSFET technology, the power amplifiers feature high linearity, excellent efficiency and compact design. The power supply is integrated into the amplifier module, which is an enclosed unit. There is practically no heat dissipated in the rack since the air circulates within the amplifier module by means of a radial

blower and the residual heat is conveyed to the cooling system via a heat exchanger.

Protective circuits against reflection, overtemperature etc are provided. The junction temperature of the transistors is around 120°C under normal operating conditions and at an ambient temperature of 25°C.

Exciter

The new exciter comprises the following modules:

- ◆ Encoder for analog TV, DVB-T or ATSC
- ◆ Digital precorrector
- ◆ Modulator
- ◆ Synthesizer
- ◆ Controller
- ◆ Control unit
- ◆ Motherboard
- ◆ Power supply

A NICAM module and a GPS module can be installed as options.

Since the modules are very compact, two complete exciters including the associated automatic switchover unit can be accommodated in a 19" mainframe of 7 height units. Each exciter has its own power supply so that full redundancy is ensured. The fully digital precorrection can be reproduced to the full. No adjustments are required after module replacement.

The transmitter is operated with the aid of a PC software under Windows or via a display integrated into the control unit.

Analog mode

The encoder for analog TV first converts the video and audio input signals to digital form. The processing of these signals according to the associated TV or colour coding standard is digital which provides for high stability and easy correction.

The encoder uses digital filters to convert the processed video signal and the sound subcarriers separately for signal display with inphase and quadrature signal.

DVB-T mode

The encoder for DVB-T is integrated in a single module. It has four physical ASI interfaces which in pairs form a complete processing path (input interface, FEC and delay). The encoder is thus prepared for hierarchical modulation. For non-hierarchical coding the two paths can be selected as a main and a standby path.

The encoder can be used both in multi-frequency networks and single-frequency

networks. For single-frequency networks a GPS receiver is integrated.

ATSC mode

The ATSC encoder module comprises data randomizer, Reed-Solomon encoder, data interleaver, Trellis encoder, MUX and pilot insertion. Channel coding and modulation are in line with Doc. ATSC-A53.

Equalizer

All versions of the encoder transfer the digital inphase and quadrature signals with a resolution of 12 bit to the digital precorrector. The precorrector is divided into two sections:

- ◆ The group-delay equalizer can compensate the group delay which occurs, for example, in power filters or vision/sound duplexers
- ◆ The linearity precorrector can precorrect the instantaneous signal amplitude and phase

Since the precorrection is digital, the reproducibility is 100% even if modules are replaced.

Central control unit

The central control unit accommodated in the exciter rack ensures control and monitoring of the whole transmitter. This central control unit enables the user to access the parameters of the whole system, in particular those of the integrated encoders, via the control panel. In this way, only one remote control interface is required to monitor all functional units of the transmitter.

Cooling system

The standard cooling system (as an external unit outside the transmitter rack) comprises a pumping set for each transmitter rack. The pumping set consists of two pumps operating in series for full redundancy, a control unit and a mixer. A cooler is installed outside the transmitter room for each pumping set. The cooler is fitted with two fans operating in active standby for redundancy. The cooling agent used is AntifrogenN.

Block diagram of cooling system

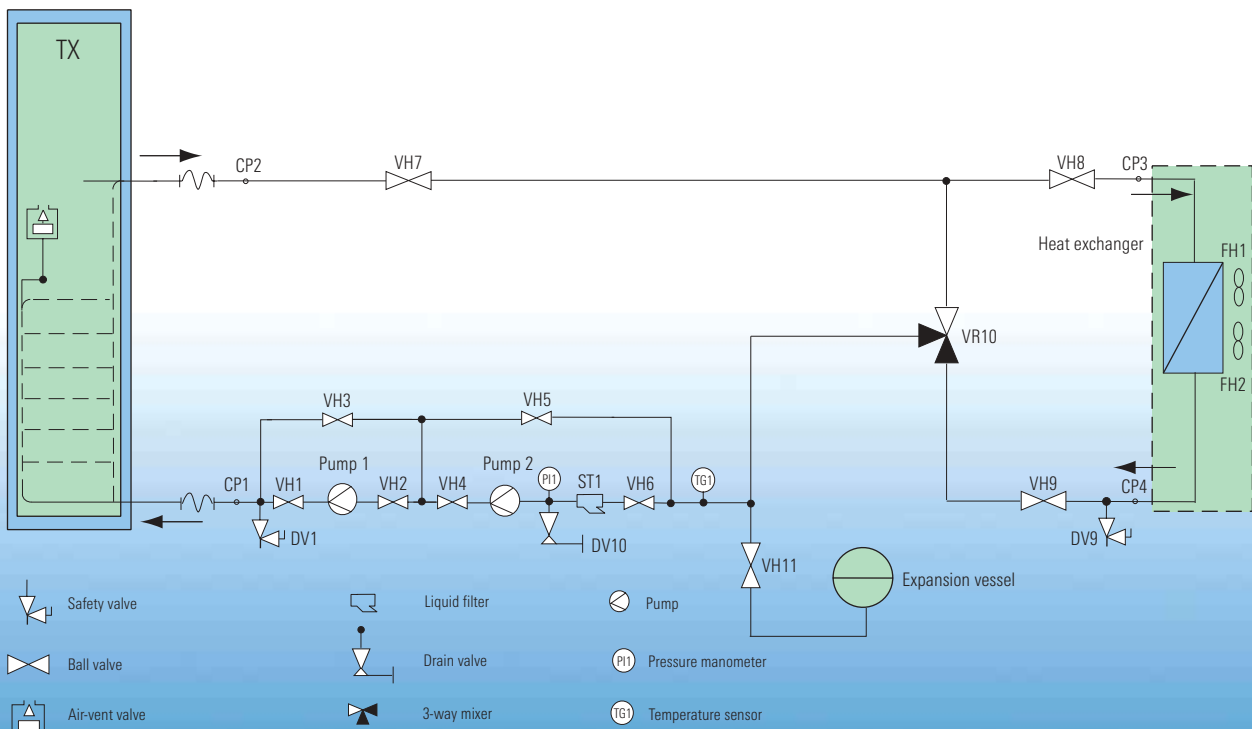

Specifications

Common data for R&S NM/NW 7000

Frequency range	170 MHz to 250 MHz	Analog TV	
Power supply	230/400 V ±15%, 50 (60) Hz ±2%	TV standards	B, D, I, K, M, N
Max. installation altitude	2000 m above sea level (>2000 m on request)	Colour transmission	PAL, NTSC, SECAM
Operating temperature range	+1°C to 45°C	Sound transmission	dual-sound coding to IRT or FM single – sound and NICAM 728 (–13 dB / –20 dB) or FM single – single sound (–10 dB)
Outside temperature range	–30°C to +50°C		
Permissible relative air humidity	95%		
Inputs		DVB-T	
Analog TV	2 x video (BNC, 75 Ω), 2 x sound (XLR, 3-contact)	IFFT mode	coding and modulation according to EN300744
DVB-T	2 x ASI (in pairs, prepared for hierarchical modulation)	Useful symbol period	2k and 8k
ATSC	2 x SMPTE-310 (BNC, 75 Ω)	Modulation	224 μs (2k) or 896 μs (8k)
		Guard interval	QPSK, 16QAM or 64QAM
			1/4, 1/8, 1/16 or 1/32 of useful symbol period
Interfaces		Inner code rate	1/2, 2/3, 3/4, 5/6 or 7/8
RS-232-C	at the front, operation of transmitter by means of graphical user interface (GUI) from PC, sub-D, female, 9-contact	Hierarchical coding	option on request
RS-485	for remote control of transmitter, at transmitter top, sub-D, female, 9-contact		
RS-232-C	for remote control of transmitter, at transmitter top, sub-D, female, 9-contact (connection of Hayes- compatible modem)	ATSC	
Optional	parallel remote-control interface, float- ing, for messages and commands; SNMP interface and/or TCP/IP Web server	Modulation	according to Doc. A53/1995
		Symbol rate	8VSB
		Data rate	10.76 MHz
		Trellis coding	19.39 Mbit/s
		Reed-Solomon encoder	2/3
			207/187/10



Specifications of R&S NM7000 (analog TV)

	R&S NM7020	R&S NM7050	R&S NM7100	R&S NM7200
RF output power ^{*)}	2 kW	5 kW	10 kW	20 kW
Number of vision amplifiers	2 (sound and video)	3	5	10
Number of sound amplifiers	–	1	1	2
Cooling	liquid-cooled			
Dimensions in mm (W x H x D)	630 x 2167 x 1200			1260 x 2167 x 1200
RF connectors	EIA 1 5/8"		EIA 3 1/8"	
Reference frequency	1 MHz, 5 MHz or 10 MHz, 0.1 V to 5 V (V _{pp}) or TTL, BNC			
Bandwidth	6 MHz, 7 MHz and 8 MHz			

Specifications of R&S NW7000 (DVB-T, ATSC)

	R&S NW7080	R&S NW7140	R&S NW7270	R&S NW7280	R&S NW7360	R&S NW7550	R&S NW7720
RF output power ^{*)} (DVB-T)	900 W	1.4 kW	2.3 kW	2.8 kW	3.6 kW	5.5 kW	7.2 kW
RF output power ^{*)} (ATSC)	1.5 kW	2.2 kW	3.7 kW	4.4 kW	5.8 kW	8.8 kW	11.5 kW
Number of amplifiers	2	3	5	6	8	12	16
Cooling	liquid cooled						
Dimensions in mm (W x H x D)	630 x 2167 x 1200					1260 x 2167 x 1200	
RF connectors	EIA 1 5/8"					EIA 3 1/8"	
Reference frequency	1 MHz, 5 MHz or 10 MHz, 0.1 V to 5 V (V _{pp}) or TTL, BNC						
Bandwidth	7 MHz and 8 MHz for DVB-T; 6 MHz for ATSC						
Reference pulse	1 Hz, TTL, BNC						

^{*)} Other power ratings on request.



ROHDE & SCHWARZ GmbH & Co. KG · Mühlendorfstraße 15 · 81671 München · Germany · P.O.B. 8014 69 · 81614 München · Germany · Telephone +49 89 4129-0
www.rohde-schwarz.com · Customer Support: Telephone +49 1805124242, Fax +49 89 4129-13777, E-mail: CustomerSupport@rohde-schwarz.com